



STRUT MOUNT

Installation Guidelines

Part No. ISST010

Suitable for Mitsubishi:
Triton ML/MN, MQ,
Challenger (Pajero Sport 2009+)

Struts:
12715GR, 24715FE

Springs:
MITS040S, MITS040A,
MITS040B, MITS040C

WARNING:

DO NOT LOOSEN OR REMOVE CENTRE TOP NUT UNTIL ALL SPRING TENSION HAS BEEN CONTAINED USING A HIGH QUALITY STRUT SPRING COMPRESSOR.

- Refer to vehicle manufacturers workshop manual for detailed removal and installation instructions.
- Expert knowledge and special tools will be required
- Follow assembly illustration as a guide only.
- Use newly supplied bushes and washers during re-assembly. Assemble in the order shown below.
- Ensure top nut is tightened fully with coil still compressed by a strut spring compressor.

Carefully align the top plate and lower strut bush to suit vehicle mount before releasing from strut spring compressor.

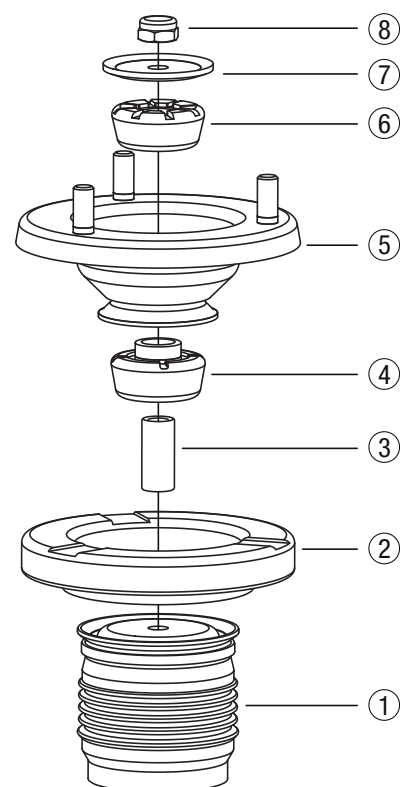
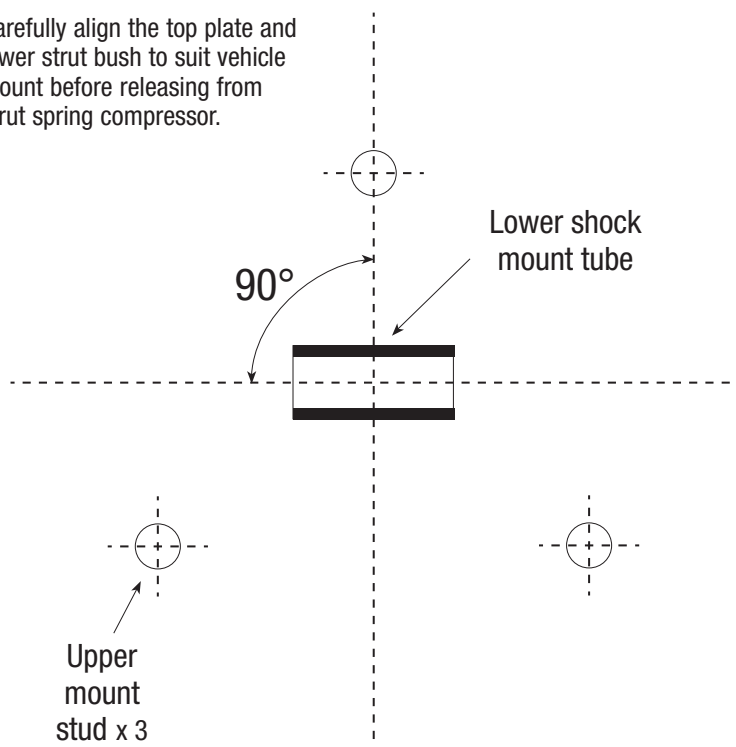

*Warranty will be voided by damage or failure caused by incorrect procedure.
Before proceeding to install strut mounts please fully read guidelines above and ensure that necessary tools are on hand.*

Always wear personal safety protection ie. Safety glasses and gloves to prevent injury.